

Z



General Purpose Basic Switch

- Best Selling General Purpose Basic Switch
- High precision switch in a variety of styles
- Available in general purpose or drip-proof models
- Available in micro load and 15 Amp models
- Molded terminal-type models incorporate a protective cover over terminals
- Wide range of variations in contact form: basic, split contact, maintained contact, and adjustable contact gap

Part	Rated Resistive Load - Switch	Actuator types	Contact form	Operating Force	Seal type	Termination Style	Service Life - Electrical (Min. @ Rated Loads)
Z-01HD-B	0.1A @ 125VAC	Short spring plunger	SPDT	250g	Unsealed	Screw Terminals	500,000 ops
Z-01HD-K	0.1A @ 125VAC	Short spring plunger	SPDT	250g	Unsealed	Screw Terminals	500,000 ops
Z-01HQ-B7-K	0.1A @ 125VAC	Panel mount plunger	SPDT	250g	Unsealed	Screw Terminals	500,000 ops
Z-01HQ2255-B	0.1A @ 125VAC	Panel mount roller plunger	SPDT	370g	IP62	Screw Terminals	500,000 ops
Z-01HW22	0.1A @ 125VAC	Short hinge roller lever	SPDT	200g	Unsealed	Screw Terminals	500,000 ops
Z-01HW22-B	0.1A @ 125VAC	Short hinge roller lever	SPDT	150g	Unsealed	Screw Terminals	500,000 ops
Z-01HW2255	0.1A @ 125VAC	Short hinge roller lever	SPDT	200g	IP62	Screw Terminals	500,000 ops
Z-10FQ22Y-B	10A @ 250VAC	Panel mount roller plunger	SPDT	540g	Unsealed	Screw Terminals	100,000 ops
Z-10FQY-B	10A @	Panel	SPDT	455 to	Unsealed	Screw	100,000

Z-15GS-B7-K	15A @ 250VAC	Slim spring plunger	SPDT	253 to 350 grams	Unsealed	Screw Terminals	500,000 ops
Z-15GS55	15A @ 250VAC	Slim spring plunger	SPDT	254 to 350 grams	IP62	Solder	500,000 ops
Z-15GS55-B	15A @ 250VAC	Slim spring plunger	SPDT	255 to 350 grams	IP62	Screw Terminals	500,000 ops
Z-15GS55-B7-K	15A @ 250VAC	Slim spring plunger	SPDT	256 to 350 grams	IP62	Screw Terminals	500,000 ops
Z-15GS55-MD 1M	15A @ 250VAC	Slim spring plunger	SPDT	250 to 350 grams	IP62	Lead Wires - Bottom exit	500,000 ops
Z-15GS55-MR 0.5M	15A @ 250VAC	Slim spring plunger	SPDT	250 to 350 grams	IP62	Lead Wires - Right Side Exit	500,000 ops
Z-15GW	15A @ 250VAC	Hinge lever	SPDT	70g	Unsealed	Solder	500,000 ops
Z-15GW-B	15A @ 250VAC	Hinge lever	SPDT	70g	Unsealed	Screw Terminals	500,000 ops
Z-15GW-B7-K	15A @ 250VAC	Low force hinge lever	SPDT	70g	Unsealed	Screw Terminals	500,000 ops
Z-15GW-B7-K	15A @ 250VAC	Hinge lever	SPDT	70g	Unsealed	Screw Terminals	500,000 ops
Z-15GW140-B	15A @ 250VAC	Hinge lever	SPDT	70g	Unsealed	Screw Terminals	500,000 ops
Z-15GW2	15A @ 250VAC	Hinge roller lever	SPDT	130g	Unsealed	Solder	500,000 ops
Z-15GW2-B	15A @ 250VAC	Hinge roller lever	SPDT	130g	Unsealed	Screw Terminals	500,000 ops
Z-15GW2-B	15A @ 250VAC	Hinge roller lever	SPDT	130g	Unsealed	Screw Terminals	500,000 ops
Z-15GW2-B7-K	15A @ 250VAC	Hinge roller lever	SPDT	130g	Unsealed	Screw Terminals	500,000 ops
Z-15GW2-B7-K	15A @ 250VAC	Hinge roller lever	SPDT	130g	Unsealed	Screw Terminals	500,000 ops
Z-15GW2155-B	15A @ 250VAC	Long hinge lever	SPDT	160g	IP62	Screw Terminals with cover	500,000 ops
Z-15GW22	15A @ 250VAC	Short hinge roller lever	SPDT	200g	Unsealed	Solder	500,000 ops

Snap Action Switch

Z

General Purpose Snap Action Switch

- High precision basic switch in a variety of styles
- Wide margins of operating conditions increasing the operating speed range
- Available in general purpose and drip-proof types
- Available in micro-load models







Ordering Information



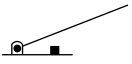









List of Models

Basic Models (General Purpose)

Actuator			Standard		High-sensitivity	Micro load
			G (0.5 mm)	H (0.25 mm)	H (0.25 mm)	
Pin plunger		Solder terminal	Z-15G	Z-15H	Z-01H	
		Screw terminal	Z-15G-B	Z-15H-B	Z-01H-B	
Slim spring plunger		Solder terminal	Z-15GS	Z-15HS	Z-01HS	
		Screw terminal	Z-15GS-B	Z-15HS-B	Z-01HS-B	
Short spring plunger		Solder terminal	Z-15GD	Z-15HD	Z-01HD	
		Screw terminal	Z-15GD-B	Z-15HD-B	Z-01HD-B	
Panel mount plunger		Low OP	Solder terminal	Z-15GQ3	—	—
			Screw terminal	Z-15GQ3-B	—	—
		Medium OP	Solder terminal	Z-15GQ	Z-15HQ	Z-01HQ
			Screw terminal	Z-15GQ-B	Z-15HQ-B	Z-01HQ-B
		High OP	Solder terminal	Z-15GQ8	—	—
			Screw terminal	Z-15GQ8-B	—	—
Panel mount roller plunger		Solder terminal	Z-15GQ22	Z-15HQ22	—	
		Screw terminal	Z-15GQ22-B	Z-15HQ22-B	—	
Panel mount cross roller plunger		Solder terminal	Z-15GQ21	Z-15HQ21	—	
		Screw terminal	Z-15GQ21-B	Z-15HQ21-B	—	
Short hinge lever		Solder terminal	Z-15GW21	—	—	
		Screw terminal	Z-15GW21-B	—	—	
Hinge lever		Low OF	Solder terminal	Z-15GW	Z-15HW	—
			Screw terminal	Z-15GW-B	Z-15HW-B	—
		Medium OF	Solder terminal	Z-15GW3	—	—
			Screw terminal	Z-15GW3-B	—	—
		High OF	Solder terminal	Z-15GW32	—	—
			Screw terminal	Z-15GW32-B	—	—
Low-force hinge lever		Solder terminal	Z-15GW4	Z-15HW24	—	
		Screw terminal	Z-15GW4-B	Z-15HW24-B	—	

Actuator		Standard		High-sensitivity	Micro load
		G (0.5 mm)		H (0.25 mm)	H (0.25 mm)
Low-force wire hinge lever 	Low OF	Solder terminal	—	Z-15HW78	—
		Screw terminal		Z-15HW78-B	
	High OF	Solder terminal	—	Z-15HW52	—
		Screw terminal		Z-15HW52-B	
Short hinge roller lever 		Solder terminal	Z-15GW22	Z-15HW22	Z-01HW22
		Screw terminal	Z-15GW22-B	Z-15HW22-B	Z-01HW22-B
Hinge roller lever 		Solder terminal	Z-15GW2	Z-15HW2	—
		Screw terminal	Z-15GW2-B	Z-15HW2-B	
Unidirectional short hinge roller lever 		Solder terminal	Z-15GW2277	—	—
		Screw terminal	Z-15GW2277-B		

Basic Models (Drip-proof Models)

Actuator		Basic model (drip-proof)		
			Standard	Micro load
			G (0.5 mm)	H (0.25 mm) Without drip-proof terminal protective cover
Pin plunger 	Solder terminal	Z-15G55	Z-01H55	
	Screw terminal	Z-15G55-B	Z-01H55-B	
Short spring plunger 		Solder terminal	Z-15GD55	Z-01HD55
		Screw terminal	Z-15GD55-B	Z-01HD55-B
Spring plunger 	Medium OP	Solder terminal	Z-15GK55	—
		Screw terminal	Z-15GK55-B	
	High OP	Solder terminal	Z-15GK355	—
		Screw terminal	Z-15GK355-B	
Panel mount plunger 		Solder terminal	Z-15GQ55	—
		Screw terminal	Z-15GQ55-B	
Panel mount roller plunger 		Solder terminal	Z-15GQ2255	—
		Screw terminal	Z-15GQ2255-B	
Panel mount cross roller plunger 		Solder terminal	—	—
		Screw terminal	Z-15GQ2155-B	
Short hinge lever 		Solder terminal	Z-15GW2155	—
		Screw terminal	Z-15GW2155-B	
Long hinge lever 		Solder terminal	Z-15GW4455	—
		Screw terminal	Z-15GW4455-B	
Hinge lever 		Solder terminal	Z-15GW55	—
		Screw terminal	Z-15GW55-B	
Short hinge roller lever 		Solder terminal	Z-15GW2255	Z-01HW2255
		Screw terminal	Z-15GW2255-B	Z-01HW2255-B
Hinge roller lever 		Solder terminal	Z-15GW255	—
		Screw terminal	Z-15GW255-B	
Unidirectional short hinge roller lever 		Solder terminal	Z-15GW227755	—
		Screw terminal	Z-15GW227755-B	
Flexible rod (coil spring) (see note 1) 		Solder terminal	Z-15GNJ55	—
		Screw terminal	Z-15GNJ55-B	

Note: The tip is made of resin.

Basic Models (Drip-proof High-sensitivity Models)

Actuator		High-sensitivity	
		H (0.25 mm)	
Flexible rod (steel wire) 	Solder terminal	Z-15HNJS55	
	Screw terminal	Z-15HNJS55-B	

Specifications

■ Characteristics

Item		Basic (except micro load and flexible rod)/ maintained contact Z-15	Basic (micro load) Z-01H	Basic (flexible rod) Z-15
Operating speed (see note)		0.01 mm to 1 m/s (see note 1)		1 mm to 1 m/s
Operating frequency	Mechanical	240 operations/min		120 operations/min
	Electrical	20 operations/min		20 operations/min
Insulation resistance		100 MΩ min. (at 500 VDC)		
Contact resistance		15 mΩ max. (initial value)	15 mΩ max. (initial value)	15 mΩ max. (initial value)
Dielectric strength		Between contacts of same polarity Contact gap G: 1,000 VAC, 50/60 Hz for 1 min Contact gap H: 600 VAC, 50/60 Hz for 1 min Between current-carrying metal parts and ground, and between each terminal and non-current-carrying metal parts 2,000 VAC, 50/60 Hz for 1 min		Between contacts of same polarity Contact gap G: 1,000 VAC, 50/60 Hz for 1 min Contact gap H: 600 VAC, 50/60 Hz for 1 min Between current-carrying metal parts and ground, and between each terminal and non-current-carrying metal parts 2,000 VAC, 50/60 Hz for 1 min
Vibration resistance	Malfunction	10 to 55 Hz, 1.5-mm double amplitude (see note 4)		10 to 20 Hz, 1.5-mm double amplitude (see note 4)
Shock resistance	Destruction	1,000 m/s ² {approx. 100G} max.		1,000 m/s ² {approx. 100G} max.
	Malfunction	300 m/s ² {approx. 30G} max. (see note 2, 4)		50 m/s ² {approx. 5G} max. (see note 4)
Life expectancy	Mechanical	20,000,000 operations min. (see note 3)		1,000,000 operations min.
	Electrical	500,000 operations min.		100,000 operations min.
Degree of protection		General-purpose: IP00 Drip-proof: IP62		
Degree of protection against electric shock		Class I		
Proof tracking index (PTI)		175		
Switch category		D (IEC335-1)		
Ambient temperature		Operating: General-purpose: -25°C to 80°C (with no icing) Drip-proof: -15°C to 80°C (with no icing)		
Ambient humidity		Operating: General-purpose: 35% to 85% Drip-proof: 35% to 95%		
Weight		Approx. 22 to 58 g		Approx. 42 to 48 g

Note: 1. The values are for the plunger models. (For the lever models, the values are at the plunger section.)
(Contact your OMRON representative for other models.)

2. The values are for the Z-15G pin plunger.

3. The values are for the pin plunger. The life expectancy for models other than the pin plunger is 10,000,000 min.

4. Malfunction: 1 ms max.

■ Operating Characteristics — Z Series Accessories (Levers/Plungers)

Characteristics	Model				
	ZAA-1 w/Z-15G-B	ZAA-2 w/Z-15G-B	ZAQ-3 w/Z-15G-B	ZAQ-2 w/Z-15G-B	ZAQ-1 w/Z-15G-B
OF max.	500 g		550 g		
RF min.	170 g		144 g		
PT max.	—		1 mm (0.04 in)		
OT min.	12.7 mm (0.50 in)		4.5 mm (0.18 in)		20.4 mm (0.80 in)
MD max.	2.2 mm (0.09 in)		0.2 mm (0.01 in)		
FP max.	34.5 mm (1.36 in)	46.1 mm (1.81 in)	—		
OP	28.9 ± 1.6 mm (1.14 ± 0.06 in)	40.4 ± 1.6 mm (1.60 ± 0.06 in)	27.8 ± 1.5 mm (1.09 ± 0.06 in)	53.2 ± 1.5 mm (2.09 ± 0.06 in)	69.1 ± 1.5 mm (2.72 ± 0.06 in)

■ Terminal Enclosures — Standard Models

Material	Mounting method	For solder terminal	For screw terminal	Remarks
Phenolic resin	Side mounting	AP-A	AP-B	—
Metal		AP1-A	AP1-B	Use in conjunction with AP-A and AP-B
Polyvinyl chloride		AP-Z	AP-Z	Excels in safety and dust-proofing property

■ Contact Information

Type	Contact gap	Features
General purpose	H: 0.25 mm (high sensitivity)	Pin plunger and lever types available. Drip-proof and flexible rod types are also available.
	G: 0.5 mm (standard)	
Drip-proof	H: 0.25 mm (high sensitivity)	The pin plunger is sealed from the other switch mechanisms by a resilient rubber, and the case and cover are sealed by adhesive so that the switch is resistant to humidity, oil and dust. The degree of protection conforms to IEC IP63.
	G: 0.5 mm (standard)	

■ Ratings

Z-15 (Except Flexible Rod Models)

Item Model	Rated voltage	Non-inductive load				Inductive load			
		Resistive load		Lamp load		Inductive load		Motor load	
		NC	NO	NC	NO	NC	NO	NC	NO
G, H	125 VAC	15 (10) A (see note)		3 A	1.5 A	15 (10) A (see note)		5 A	2.5 A
	250 VAC	15 (10) A (see note)		2.5 A	1.25 A	15 (10) A (see note)		3 A	1.5 A
	500 VAC	10 A		1.5 A	0.75 A	6 A		1.5 A	0.75 A
G	8 VDC	15 A		3 A	1.5 A	15 A		5 A	2.5 A
	14 VDC	15 A		3 A	1.5 A	10 A		5 A	2.5 A
	30 VDC	6 A		3 A	1.5 A	5 A		5 A	2.5 A
	125 VDC	0.5 A		0.5 A	0.5 A	0.05 A		0.05 A	0.05 A
	250 VDC	0.25 A		0.25 A	0.25 A	0.03 A		0.03 A	0.03 A
H	8 VDC	15 A		3 A	1.5 A	15 A		5 A	2.5 A
	14 VDC	15 A		3 A	1.5 A	10 A		5 A	2.5 A
	30 VDC	2 A		2 A	1.4 A	1 A		1 A	1 A
	125 VDC	0.4 A		0.4 A	0.4 A	0.03 A		0.03 A	0.03 A
	250 VDC	0.2 A		0.2 A	0.2 A	0.02 A		0.02 A	0.02 A

Note: Figures in parenthesis are for Z-15HW52 and Z-15HW78(-B) models, the AC ratings of these models are 125 and 250 V only.

Z-15 (Flexible Rod Models)

Rated voltage	Non-inductive load				Inductive load			
	Resistive load		Lamp load		Inductive load		Motor load	
	NC	NO	NC	NO	NC	NO	NC	NO
125 VAC	15 A		2 A	1 A	7 A		2.5 A	2 A
250 VAC			1 A	0.5 A	5 A		1.5 A	1 A
8 VDC	15 A		2 A	1 A	7 A		3 A	1.5 A
14 VDC	15 A		2 A	1 A	7 A		3 A	1.5 A
30 VDC	2 A		2 A	1 A	1 A		1 A	0.5 A
125 VDC	0.4 A		0.4 A	0.4 A	0.03 A		0.03 A	0.03 A
250 VDC	0.2 A		0.2 A	0.2 A	0.02 A		0.02 A	0.02 A

Z-01H

Rated Voltage	Resistive load	
	NC	NO
125 VAC	0.1 A	
8 VDC	0.1 A	
14 VDC	0.1 A	
30 VDC	0.1 A	

Using Micro Loads

Using a model for ordinary loads to open or close the contact of a micro load circuit may result in faulty contact. Use models that operate in the following range. However, even when using micro load models within the operating range shown here, if inrush current occurs when the contact is opened or closed, it may increase contact wear and so decrease life expectancy. Therefore, insert a contact protection circuit where necessary.

The minimum applicable load is the N-level reference value. This value indicates the malfunction reference level for the reliability level of 60% ($\lambda 60$). The equation, $\lambda 60 = 0.5 \times 10^{-6}/\text{operations}$ indicates that the estimated malfunction rate is less than 1/2,000,000 operations with a reliability level of 60%.

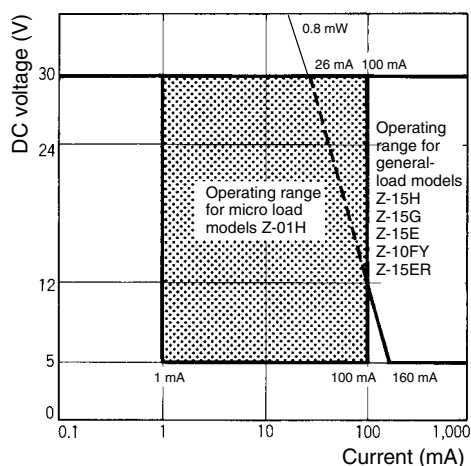

Item	Z-01H	Z-15□, Z-10FY
Minimum applicable load	1 mA at 5 VDC	160 mA at 5 VDC

Contact Form

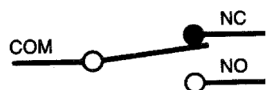

Approval Standards

UL508 (File No. E41515)

CSA C22.2 No.55 (File No. LR21642)

Rated voltage	Z-15	Z-01H
125 VAC	15 A 1/8 HP	0.1 A
250 VAC	15 A 1/4 HP	—
480 VAC	15 A	—
30 VDC	—	0.1 A
125 VDC	0.5 A	—
250 VDC	0.25 A	—

EN (EN61058-1)

Rated voltage	Z-15H□-B	Z-15G□-B	Z-01H□-B
250 VAC	15 A	15 A	—
125 VAC	—	—	0.1 A
30 VDC	—	—	0.1 A

Note: Consult with Omron about approved part numbers by standards.

Drip-proof Construction

Without Terminal Protective Cover

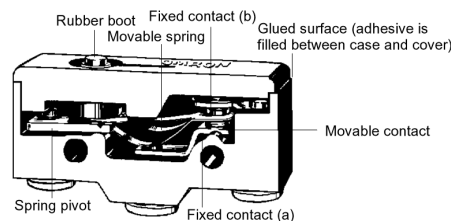

With Terminal Protective Cover

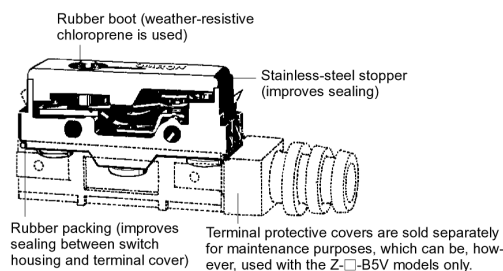

Engineering Data

Mechanical Life Expectancy

Z-15G

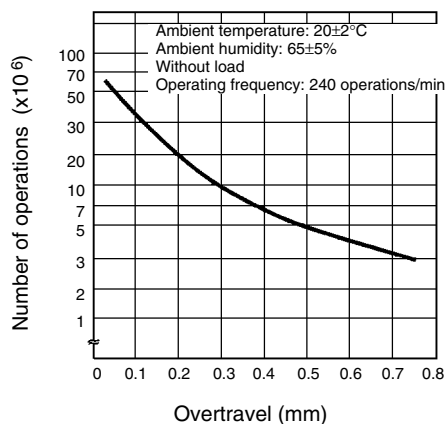

Electrical Life Expectancy

Z-15G

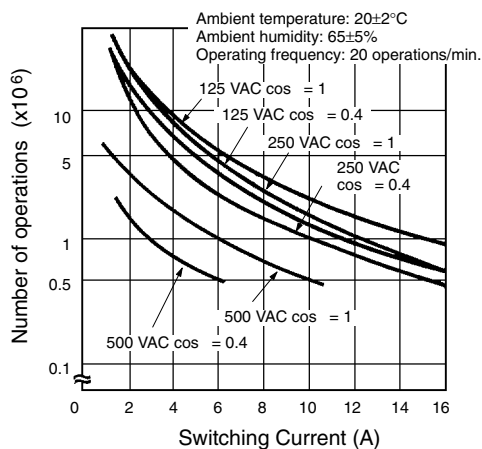

Dimensions

- Note:**
- All units are in millimeters unless otherwise indicated.
 - Unless otherwise specified, a tolerance of ± 0.4 mm applies to all dimensions.

Basic Models (General-purpose)

Terminals

Basic (general-purpose) models	
<p>Screw terminals (-B)</p> <p>Three, M4 × 5.5 Terminal screws (with toothed washer)</p> <p>Appropriate terminal screw tightening torque: 0.78 to 1.18 N • m {8 to 12 kgf • cm}.</p>	<p>Solder terminal</p>
<p>Note: With reverse action models (Z-15GM), the positions of NO and NC terminals are reversed.</p>	

Mounting Holes

Dimensions and Operating Characteristics

The models, illustrations, and graphics are for screw-terminal models (-B). The “-A” at the end of the model number for solder terminal models has been omitted. For details of the terminals, refer to *Terminals* above.

Pin Plunger

Z-15G-B, Z-15E-B
Z-15H-B, Z-01H-B

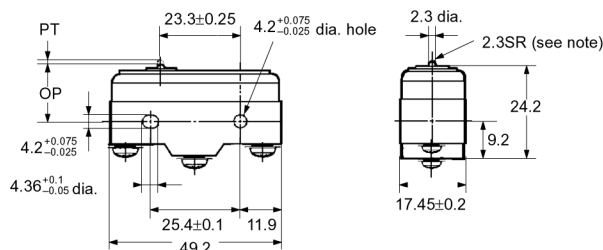

Note: Stainless-steel plunger

	Z-15G-B	Z-15H-B	Z-15E-B	Z-01H-B
OF	2.45 to 3.43 N {250 to 350 gf}	1.96 to 2.75 N {200 to 280 gf}	6.12 to 7.85 N {625 to 800 gf}	2.45 N {250 gf} max.
RF min	1.12 N {114 gf}	1.12 N {114 gf}	1.12 N {114 gf}	0.78 N {80 gf}
PT max.	0.4 mm	0.3 mm	0.8 mm	0.5 mm
OT min.	0.13 mm	0.13 mm	0.13 mm	0.13 mm
MD max.	0.05 mm	0.025 mm	0.13 mm	0.04 mm
OP	15.9 ± 0.4 mm			

Slim Spring Plunger

Z-15GS-B, Z-15HS-B,
Z-01HS

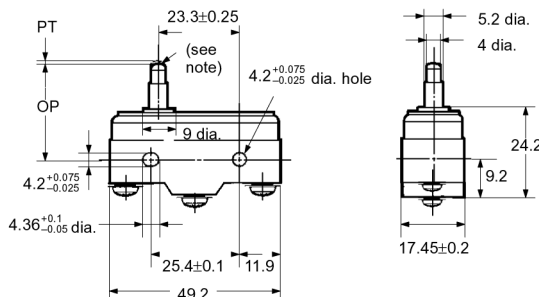
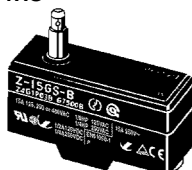

Note: Stainless-steel plunger
(flat, 1R chamfered)

	Z-15GS-B	Z-15HS-B	Z-01HS
OF	2.45 to 3.43 N {250 to 350 gf}	1.96 to 2.79 N {200 to 285 gf}	2.45 N {250 gf} max.
RF min	1.12 N {114 gf}	1.12 N {114 gf}	0.78 N {80 gf}
PT max.	0.4 mm	0.3 mm	0.5 mm
OT min.	1.6 mm	1.6 mm	1.6 mm
MD max.	0.05 mm	0.025 mm	0.05 mm
OP	28.2 ± 0.5 mm		

Short Spring Plunger

Z-15GD-B, Z-15HD-B,
Z-01HD-B, Z-15ED-B

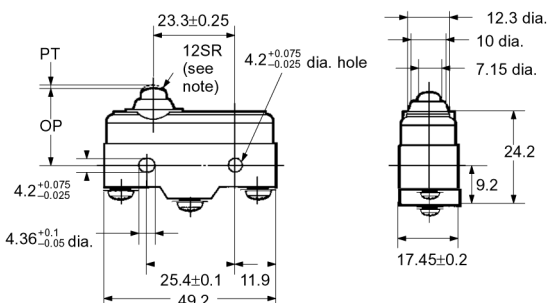
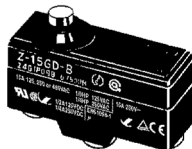

Note: Plated iron plunger

	Z-15GD-B	Z-15HD-B	Z-15ED-B	Z-01HD-B
OF	2.45 to 3.43 N {250 to 350 gf}	1.96 to 2.79 N {200 to 285 gf}	6.13 to 7.85 N {625 to 800 gf}	2.45 N {250 gf} max.
RF min	1.12 N {114 gf}	1.12 N {114 gf}	1.12 N {114 gf}	0.78 N {80 gf}
PT max.	0.4 mm	0.3 mm	0.8 mm	0.5 mm
OT min.	1.6 mm	1.6 mm	1.6 mm	1.6 mm
MD max.	0.05 mm	0.025 mm	0.13 mm	0.05 mm
OP	21.5 ± 0.5 mm			

Panel Mount Plunger

Z-15GQ-B, Z-01HQ-B,
Z-15HQ-B, Z-15EQ-B

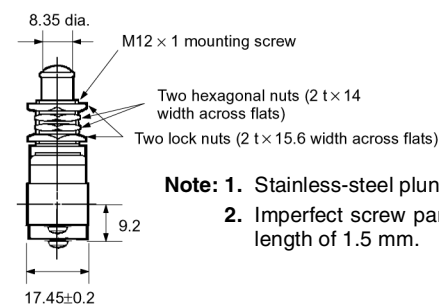
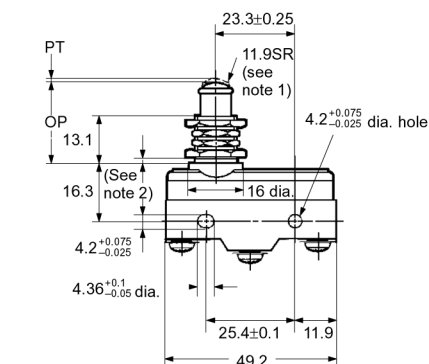
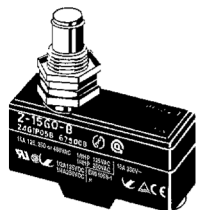

- Note: 1.** Stainless-steel plunger
Note: 2. Imperfect screw part with a maximum length of 1.5 mm.

Z-15GQ3-B

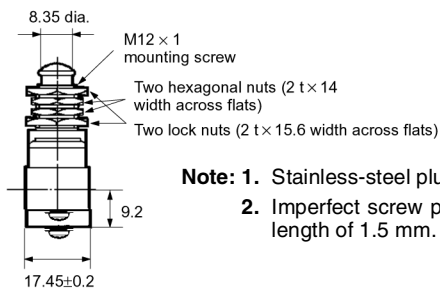
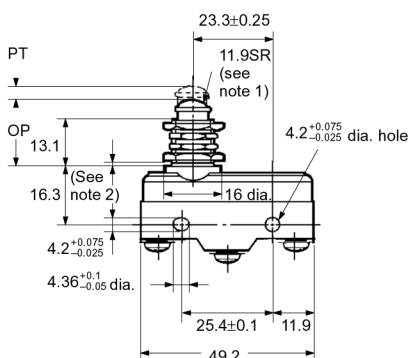
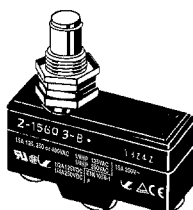

- Note: 1.** Stainless-steel plunger
Note: 2. Imperfect screw part with a maximum length of 1.5 mm.

Z-15GQ8-B

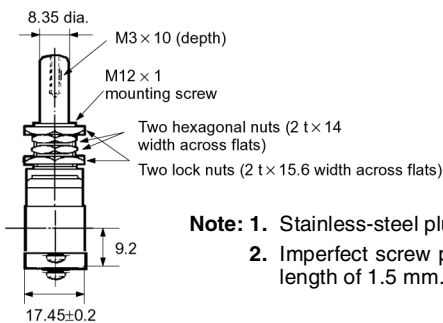
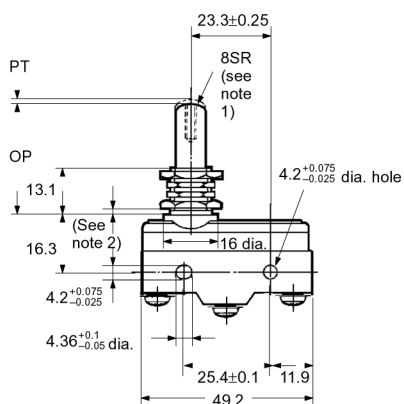
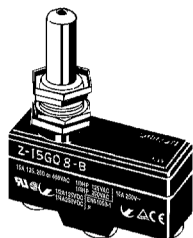

- Note: 1.** Stainless-steel plunger
Note: 2. Imperfect screw part with a maximum length of 1.5 mm.

	Z-15GQ-B	Z-15HQ-B	Z-15EQ-B	Z-01HQ-B	Z-15GQ3-B	Z-15GQ8-B
OF	2.45 to 3.43 N {250 to 350 gf}	1.96 to 2.79 N {200 to 285 gf}	6.13 to 7.85 N {625 to 800 gf}	2.45 N {250 gf} max.	2.45 to 3.43 N {250 to 350 gf}	2.45 to 3.43 N {250 to 350 gf}
RF min	1.12 N {114 gf}	1.12 N {114 gf}	1.12 N {114 gf}	0.78 N {80 gf}	1.12 N {114 gf}	1.12 N {114 gf}
PT max.	0.4 mm	0.3 mm	0.8 mm	0.5 mm	4.2 mm	0.5 mm
OT min.	5.5 mm	5.5 mm	5.5 mm	5.5 mm	2.5 mm	5.5 mm
MD max.	0.05 mm	0.025 mm	0.13 mm	0.05 mm	2.2 mm	0.05 mm
OP	21.8 ± 0.8 mm				18.8 ± 0.8 mm	32.5 ± 1 mm

- Note: 1.** Do not use the M12 mounting screw and the case mounting hole at the same time, or excessive pulling force will be imposed on the Switch and the case and cover may be damaged.
Note: 2. On the model Z-15GQ3-B, PT can be set to a value larger than that for the Z-15GQ.
Note: 3. On the model Z-15GQ8-B, operating position can be adjusted by providing a screw in the plunger section. The M3 hole with a depth of 10 mm is a through hole. Take precautions so that no water or screw lock agent penetrates into the hole.

Panel Mount Roller Plunger

Z-15GQ22-B, Z-15EQ22-B,
Z-15HQ22-B

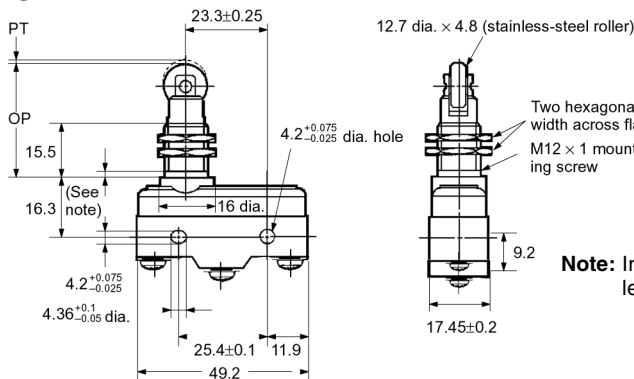
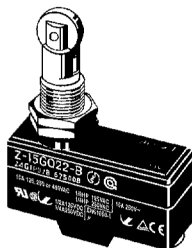

Note: Imperfect screw part with a maximum length of 1.5 mm.

	Z-15GQ22-B	Z-15HQ22-B	Z-15EQ22-B
OF	2.45 to 3.43 N {250 to 350 gf}	1.96 to 2.79 N {200 to 285 gf}	6.13 to 7.85 N {625 to 800 gf}
RF min	1.12 N {114 gf}	1.12 N {114 gf}	1.12 N {114 gf}
PT max.	0.4 mm	0.3 mm	0.8 mm
OT min.	3.58 mm	3.58 mm	3.58 mm
MD max.	0.05 mm	0.025 mm	0.13 mm
OP	33.4 ± 1.2 mm		

Note: Do not use the M12 mounting screw and the case mounting hole at the same time, or the case may be damaged.

Panel Mount Cross Roller Plunger

Z-15GQ21-B, Z-15HQ21-B,
Z-15EQ21-B

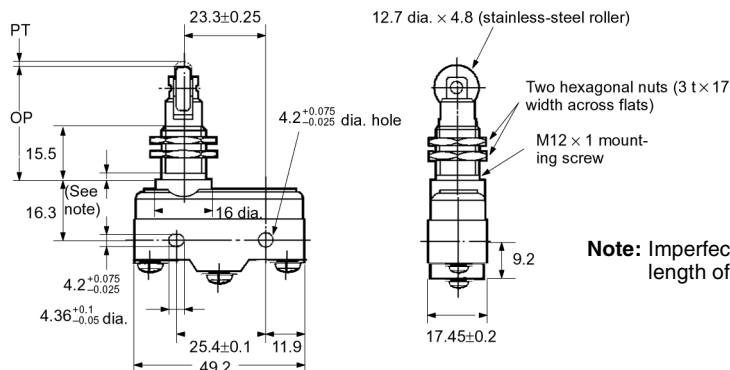
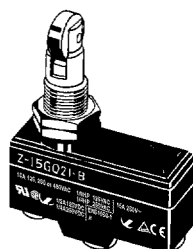

Note: Imperfect screw part with a maximum length of 1.5 mm.

	Z-15GQ21-B	Z-15HQ21-B	Z-15EQ21-B
OF	2.45 to 3.43 N {250 to 350 gf}	1.96 to 2.79 N {200 to 285 gf}	6.13 to 7.85 N {625 to 800 gf}
RF min	1.12 N {114 gf}	1.12 N {114 gf}	1.12 N {114 gf}
PT max.	0.4 mm	0.3 mm	0.8 mm
OT min.	3.58 mm	3.58 mm	3.58 mm
MD max.	0.05 mm	0.025 mm	0.13 mm
OP	33.4 ± 1.2 mm		

Note: Do not use the M12 mounting screw and the case mounting hole at the same time, or the case may be damaged.

Short Hinge Lever

Z-15GW21-B

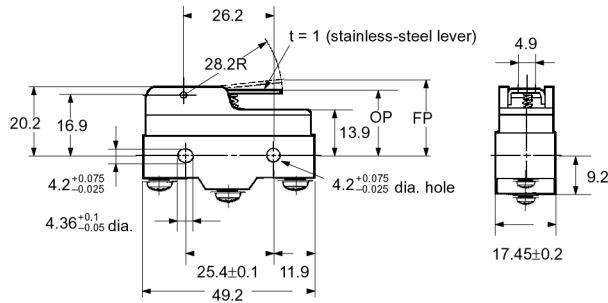
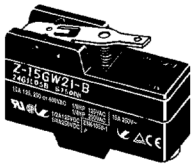

OF max.	1.57 N {160 gf}
RF min.	0.27 N {28 gf}
OT min.	2 mm
MD max.	1 mm
FP max.	24.8 mm
OP	19 ± 0.8 mm

Hinge Lever

Z-15GW-B, Z-15GW32-B,
Z-15HW-B, Z-15GW3-B (Lever length: 56R)
(see note)

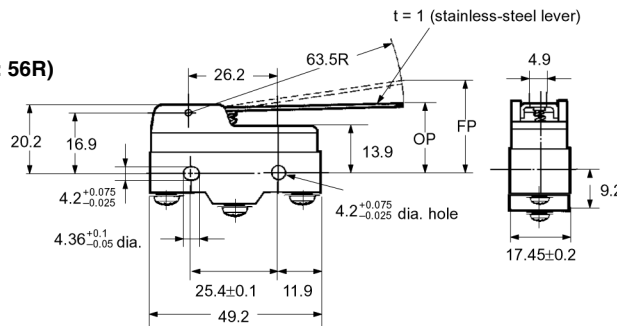
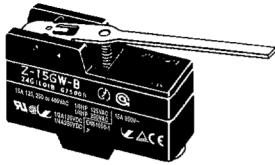

Note: The external dimensions of the actuator vary.

	Z-15GW-B	Z-15HW-B	Z-15GW32-B	Z-15GW3-B
OF max.	0.69 N {70 gf}	0.66 N {67 gf}	1.47 to 1.69 N {150 to 200 gf}	0.78 N {80 gf}
RF min.	0.14 N {14 gf}	0.14 N {14 gf}	0.92 N {94 gf}	0.15 N {15.5 gf}
OT min.	5.6 mm	5.6 mm	5.6 mm	4.8 mm
MD max.	1.27 mm	0.63 mm	1.27 mm	1.12 mm
FP max.	28.2 mm	27.4 mm	28.2 mm	27.2 mm
OP	19 ± 0.8 mm			

Low-force Hinge Lever

Z-15GW4-B

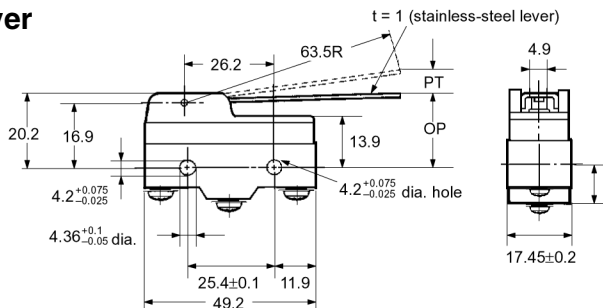
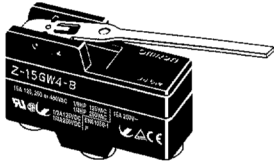

OF max.	274 mN {28 gf}
RF min.	34.3 mN {3.5 gf}
PT max.	10 mm
OT min.	5.6 mm
MD max.	1.27 mm
OP	19 ± 0.8 mm

Z-15HW24-B

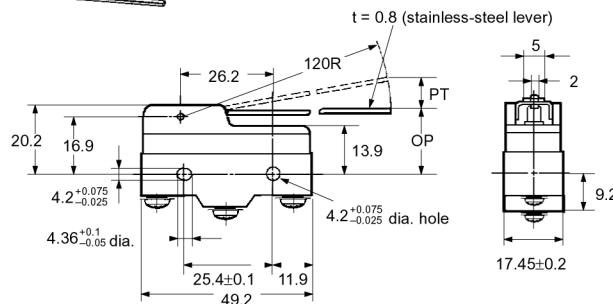
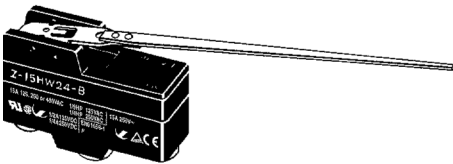

OF max.	58.8 mN {6 gf}
RF min.	4.90 mN {0.5 gf}
PT max.	19.8 mm
OT min.	10 mm
MD max.	2 mm
OP	19.8 ± 1.6 mm

Low-force Wire Hinge Lever

Z-15HW52-B

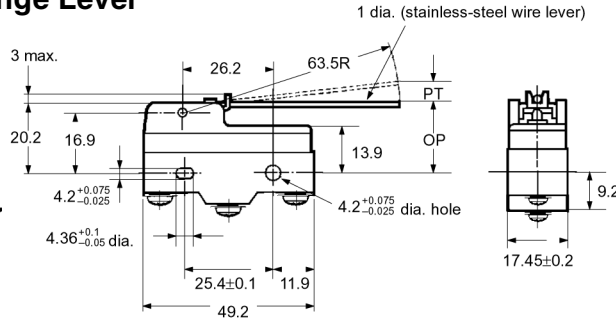
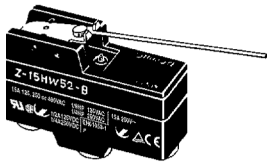

OF max.	58.8 mN {6 gf}
RF min.	4.90 mN {0.5 gf}
PT max.	8.3 mm
OT min.	5.6 mm
MD max.	0.65 mm
OP	19 ± 1 mm

Z-15HW78-B

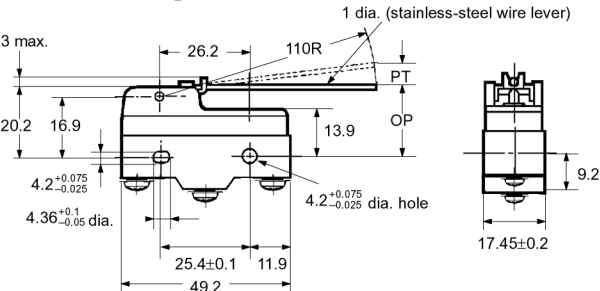
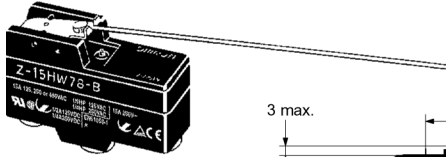

OF max.	39.2 mN {4 gf}
RF min.	2.94 mN {0.3 gf}
PT max.	10 mm
OT min.	6 mm
MD max.	3 mm
OP	20 ± 1 mm

Note: The AC rating is 10 A at 125 or 250 V.

Short Hinge Roller Lever

Z-15GW22-B, Z-01HW22-B
 Z-15HW22-B, Z-15EW22-B, Z-15GW2-B
 Z-15HW2-B (see note),
 (Lever Length: 48.5R) (see note)

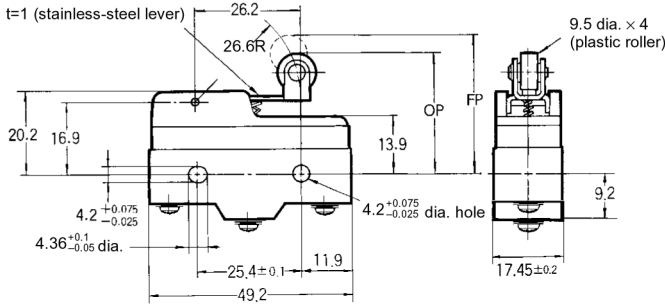
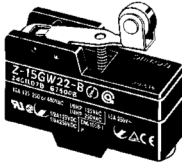

Note: The external dimensions of the actuator vary.

	Z-15GW22-B	Z-15HW22-B	Z-15EW22-B	Z-01HW22-B	Z-15GW2-B	Z-15HW2-B
OF max.	1.57 N {160 gf}	1.47 N {150 gf}	1.94 N {198 gf}	1.57 N {160 gf}	0.98 N {100 gf}	0.84 N {86 gf}
RF min.	0.41 N {42 gf}	0.41 N {42 gf}	0.41 N {42 gf}	0.27 N {28 gf}	0.22 N {22 gf}	0.22 N {22 gf}
OT min.	2.4 mm	2.4 mm	2.4 mm	2.4 mm	4 mm	4 mm
MD max.	0.5 mm	0.45 mm	1.3 mm	0.5 mm	1.02 mm	0.6 mm
FP max.	32.5 mm		35.1 mm	32.5 mm	36.5 mm	
OP	30.2 ± 0.4 mm		30.2 ± 0.4 mm	30.2 ± 0.4 mm	30.2 ± 0.8 mm	

**Unidirectional Short Hinge
Roller Lever**
Z-15GW2277-B

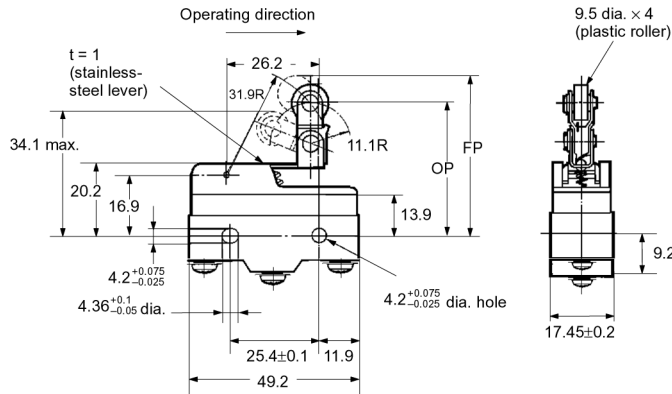
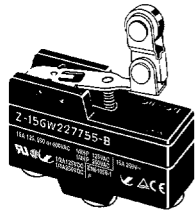

OF max.	1.67 N {170 gf}
RF min.	0.41 N {42 gf}
OT min.	2.4 mm
MD max.	0.51 mm
FP max.	43.6 mm
OP	41.3 ± 0.8 mm

Basic Models (Drip-proof) without Terminal Protective Cover

Terminals

Without Terminal Protective Cover

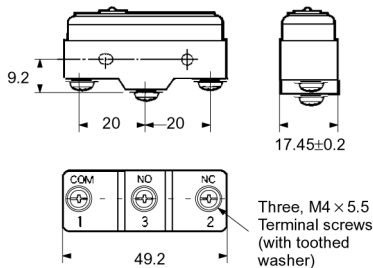

Note: With reverse action models (Z-15GM), the positions of NO and NC terminals are reversed.

Mounting Holes

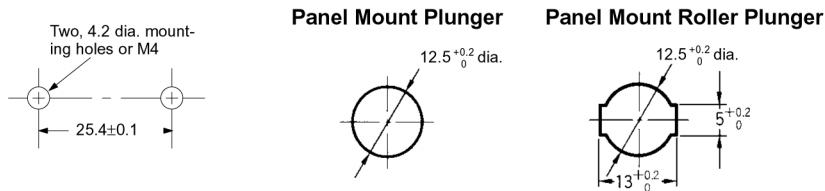

Dimensions and Operating Characteristics

Pin Plunger

Z-15G55-B
Z-01H55-B

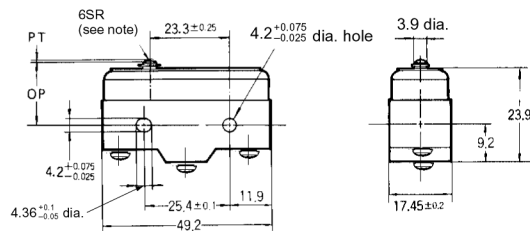

Note: Stainless-steel plunger

Model	Z-15G55-B	Z-01H55-B
OF	2.45 to 4.22 N {250 to 431 gf}	3.43 N {350 gf} max.
RF min.	1.12 N {114 gf}	0.78 N {80 gf}
PT max.	2.2 mm	2.2 mm
OT min.	0.13 mm	0.13 mm
MD max.	0.06 mm	0.06 mm
OP	15.9 ± 0.4 mm	

Panel Mount Cross Roller Plunger

Z-15GQ2155-B

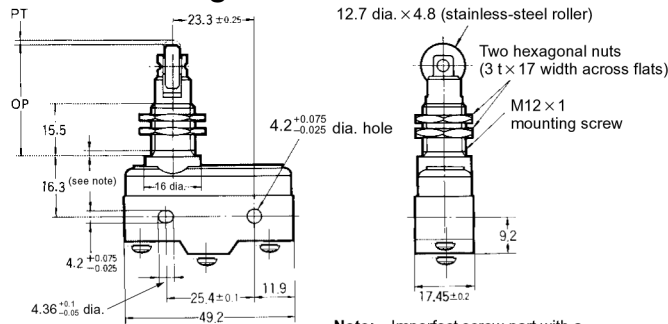
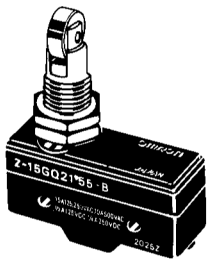

OF max.	5.30 N {541 gf}
RF min.	1.12 N {114 gf}
PT max.	1.8 mm
OT min.	3.58 mm
MD max.	0.06 mm
OP	33.4 ± 1.2 mm

Note: Imperfect screw part with a maximum length of 1.5 mm.

Note: Do not use the M12 mounting screw and the case mounting hole at the same time, or the case may be damaged.

Short Hinge Lever

Z-15GW2155-B

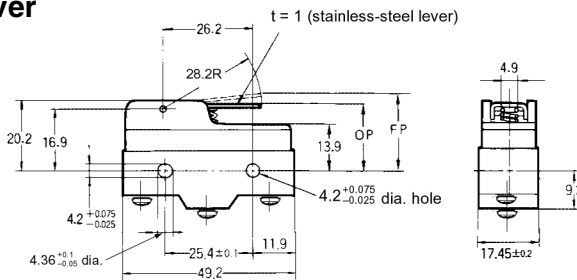
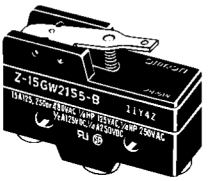

OF max.	1.86 N {190 gf}
RF min.	0.27 N {28 gf}
OT min.	2 mm
MD max.	1 mm
FP max.	25 mm
OP	19 ± 0.8 mm

Long Hinge Lever

Z-15GW4455-B

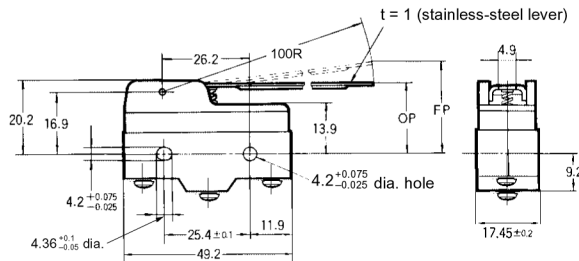
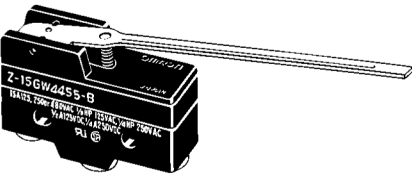

OF max.	0.88 N {90 gf}
RF min.	0.14 N {14 gf}
OT min.	5.6 mm
MD max.	3.5 mm
FP max.	33 mm
OP	19 ± 1.2 mm

Hinge Lever

Z-15GW55-B

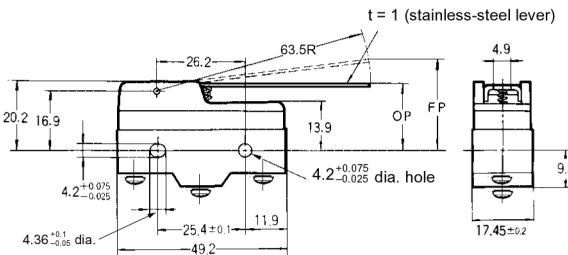
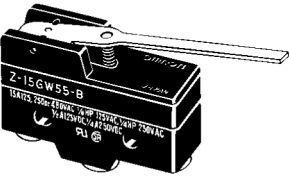

OF max.	0.98 N {100 gf}
RF min.	0.14 N {14 gf}
OT min.	5.6 mm
MD max.	2 mm
FP max.	28.2 mm
OP	19 ± 0.8 mm

Short Hinge Roller Lever

Z-15GW2255-B

Z-01HW2255-B

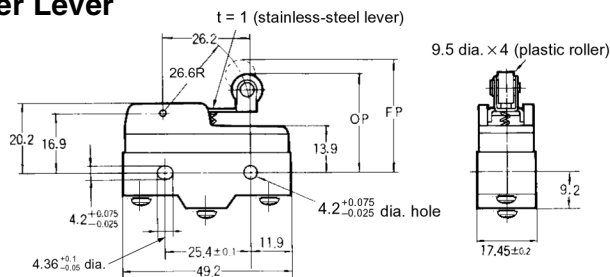
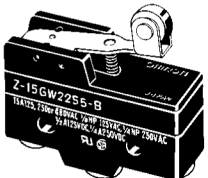

Model	Z-15GW2255-B	Z-01HW2255-B
OF max.	1.96 N {200 gf}	1.96 N {200 gf}
RF min.	0.41 N {42 gf}	0.27 N {28 gf}
OT min.	2.4 mm	2.4 mm
MD max.	0.8 mm	0.8 mm
FP max.	32.9	
OP	30.2 ± 0.4 mm	